

# MAXIMUM TRUCK LOADINGS AND DIMENSIONS

Regulations pertaining to the operation of trucks and trailers according to Act 300 P.A. 1949 as amended.

**NOTE:** *When restricted loadings are in effect, the normal maximum axle weights allowable on rigid pavements shall be reduced 25% and the maximum wheel load shall not exceed 525 pounds per inch width of tire.*

*When restricted loadings are in effect, the normal maximum axle weights allowable on flexible pavements shall be reduced 35% and the maximum wheel load shall not exceed 450 pounds per inch width of tire.*

---

## MAXIMUM OVERALL DIMENSIONS

Width .....	96 inches
Width (designated highways) .....	102 inches
Height .....	13 feet, 6 inches
Length of semi-trailer (including load) .....	53 feet
Length of a combination of truck-tractor and semi-trailer with or without load .....	no limitation
Length of any other vehicle with or without load (excluding impact absorbing bumpers) .....	40 feet
Units permitted in train...Truck-tractor, semi-trailer and trailer or truck tractor and 2 semi-trailers or truck and semi-trailer or trailer.	
Length of a combination of truck-tractor, semi-trailer and trailer or truck-tractor and 2 semi-trailers or truck and semi-trailer or trailer with or without load or pickup truck, semi-trailer designed for recreational living purposes, and additional trailer or semi-trailer (see exceptions) .....	.59 feet
Semi-trailers longer than 50 feet shall have a wheelbase of 40.5 feet plus or minus 0.5 feet, measured from the kingpin coupling to the center of the axles or to the center of the tandem axle assembly if equipped with 2 axles.	
Semi-trailers longer than 50 feet are limited to 2 axles.	
Semi-trailers longer than 50 feet shall operate on designated highways only.	
Semi-trailers and trailers shall be measured from the front vertical plane of the foremost transverse load supporting structure to the rearmost transverse load supporting structure.	
Length shall not include safety and energy conservation devices including, but not limited to, impact absorbing bumpers, rear view mirrors, turn signal lamps, marker lamps, steps and hand holds for entry and egress, flexible fender extensions, mud flaps or splash and suppressant devices, load induced tire bulge, refrigeration or heating units, or air compressors. A device shall be excluded from a determination of length only if it is not designed or used for the carrying of cargo.	
Projection beyond front of vehicles .....	3 feet
Overhang beyond rear of vehicles .....	Any amount is permissible if the legal length is not exceeded. But if this overhang is 4 feet or more, there shall be displayed on the extreme rear of such load a 12 inch red square flag in the daytime and a red light or lantern at night.
Axle limitation .....	A combination of vehicles shall not have in excess of 11 axles.

### EXCEPTIONS:

**WIDTH: Unprocessed Logs, Pulpwood, Wood Bolts, Agricultural Products, and Concrete Pipe,** 108 inches for load only; **Busses,** 102 inches; **Implements of Husbandry:** "A farmer only" may operate or move an implement of husbandry of any width on a highway as required for normal farming operations.

**LENGTH: Truck-Tractor, Semi-Trailer, and Trailer or Truck-Tractor and 2 Semi-Trailers:** No overall length limitation providing the length of each semi-trailer and trailer including load does not exceed 28 feet 6 inches or the overall length of the semi-trailer and trailer or 2 semi-trailers as measured from the front of the first towed unit to the rear of the second towed unit while the units are coupled together does not exceed an overall length of 58 feet, including load. Any such combination, except as herein described with regard to assembled motor vehicles or bodies, recreational vehicles or boats, may be operated only on such highways and routes as designated by the appropriate authorities.

**Truck and Trailer or Semi-Trailer:** Overall length not to exceed 65 feet. Any such combination may be operated only on such highways and routes as designated by the appropriate authorities.

**Truck and Trailer or Semi-Trailer:** Designed and used to transport saw logs, pulpwood, and tree length poles. Overall length not to exceed 70 feet including load. Any such combination may be operated only on such highways and routes as designated by the appropriate authorities.

**Truck-Tractor, Semi-trailer, and Trailer, or Truck Tractor and Semi-Trailer or Trailer designed and used exclusively to transport assembled motor vehicles or bodies, recreational vehicles, or boats:** Any such combination not to exceed a total length of 65 feet, except a stinger-steered combination shall not exceed a total length of 75 feet. the load on any such combination of vehicles may extend an additional 3 feet beyond the front and 4 feet beyond the rear of the combination of vehicles.

**Articulated Busses:** Articulate busses operated by a local public transit system funded by Act No. 51 of the Public Acts of 1951 as amended, may operate with a maximum length of 65 feet.

**Motor vehicles wholly or partially assembled transported by utilizing 1 tow bar or 3 saddle mounts with full mount mechanisms and using the motive power of 1 vehicle.** Any such combination of vehicles may not exceed the maximum length of 65 feet. Any combination exceed 55 feet in length may be operated only on such highways and routes as designated by appropriate authorities.

The total gross weight of any 65 foot combination of vehicles shall not exceed a ratio of 400 lbs.. per engine net horsepower delivered to clutch or its' equivalent specified in the SAE test code.

**MOBILE HOMES:** 45 feet in body length, 60 feet when in combination with a towing unit 8 feet 4 inches in width, 12 feet 6 inches in height.

**VEHICLES TRANSPORTING FLAMMABLE LIQUID, IN BULK, WHICH AS A FLASH POINT AT OR BELOW 70 DEGREES FAHRENHEIT:** Vehicles shall meet safety standards as determined by the Department of State Police. Vehicles manufactured after July 27, 1978, are limited to 11 feet 8-1/2 inches maximum height.

**Truck-Tractor, Semi-Trailer and Trailer or Truck-Tractor and 2 Semi-Trailers:** Movement not allowed within a county having a population of 600,000 or more except between the hours of midnight to 6:00 a.m. on routes and at times designated by the Department of State Police.

**Truck, or a Truck and Trailer, or a Truck-Tractor and Semi-Trailer:** Movement not allowed transporting a quantity of more than 9,000 gallons within a county having a population of 600,000 or more except between the hours of midnight to 6:00 a.m. on routes and at times designated by the Department of State Police.

**Other Tandem axles and Multi-axes**

On any other combination of vehicles exceeding a gross weight of 73,280 lbs., only one (1) tandem axle assembly shall be permitted at this weight (16,000 pounds per axle). No other tandem axle assembly shall exceed 13,000 pounds per axle.

**Public Act #300, 1949 Sec. 257.722 Paragraph 8**

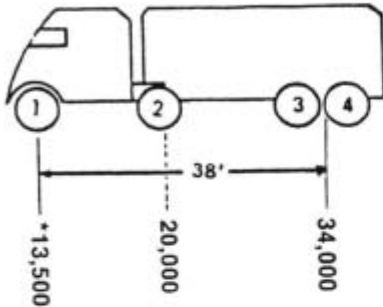

$$W = 500 \left( \frac{LN}{N - 1} + 12N + 36 \right)$$

$$W = 500 \left( \frac{38 \times 4}{4 - 1} + 12 \times 4 + 36 \right)$$

$$W = 500 \times 134.6$$

$$W = 67,300 \text{ lbs., or rounded off to nearest 500 lbs.} = 67,500$$

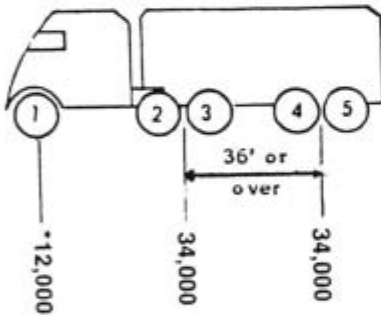

The state transportation commission, or a local authority with respect to highways under its jurisdiction, may designate a highway, or a section of a highway, for the operation of vehicles having a gross vehicle weight of not more than 80,000 pounds which do not exceed any of the following:

- (i) Twenty thousand pounds on any 1 axle.
- (ii) A tandem axle weight of 34,000 pounds including all enforcement tolerances.
- (iii) An overall gross weight on a group of 2 or more consecutive axles equaling:

$$W = 500 \left( \frac{LN + 12N + 36}{N - 1} \right)$$

where W = overall gross weight on a group of 2 or more consecutive axles to the nearest 500 pounds, L = distance in feet between the extreme of a group of 2 or more consecutive axles, and N = number of axles in the group under consideration; except that 2 consecutive sets of tandem axles may carry a gross load of 34,000 pounds each if the first and last axles of the consecutive sets of tandem axles are not less than 36 feet apart, and the gross vehicle weight does not exceed 80,000 pounds including all enforcement tolerances. Except for 5 axle truck tractor, semi-trailer combinations having 2 consecutive sets of tandem axles, vehicles having a gross weight in excess of 80,000 pounds or in excess of the vehicle gross weight determined by application of the formula in this subsection shall be subject to the maximum axle loads specified in column 2 (Normal Loading When Limitations Are Not In Force) of the chart on the preceding page.

## TABLE OF MAXIMUM ALLOWABLE GROSS AXLE LOADINGS

Spacings Between Axles	Normal Loadings When Seasonal Load Limitations Are Not In Force (Speed Limit 55 MPH)		Seasonal Load Limitations (Speed Limit 35 MPH)	
	Vehicles Exceeding 80,000 lbs. Gross Weight	†Vehicles 80,000 lbs. Or Under Gross Weight	Rigid	Flexible
9 feet or over	18,000 lbs.	20,000 lbs.	13,500 lbs.	11,700 lbs.
More than 3½ feet but less than 9 feet	13,000 lbs.	13,000 lbs.	9,750 lbs.	8,450 lbs.
When part of a tandem axle assembly	*16,000 lbs.	34,000 lbs. on tandem	**12,000 lbs.	***10,400 lbs.
When less than 3½ feet	9,000 lbs.	9,000 lbs.	6,750 lbs.	5,850 lbs.
Maximum load on any wheel shall not exceed: (pounds per inch of tire width)	700 lbs.	700 lbs.	525 lbs.	450 lbs.

† Gross vehicle weight may not exceed 80,000 lbs. and the following: An overall gross weight on a group of 2 or more consecutive axles equaling:

$$W = 500 \left( \frac{LN}{N-1} + 12N + 36 \right)$$

Where W = overall gross weight on a group of 2 or more consecutive axles to the nearest 500 pounds, L = distance in feet between the extreme of a group of 2 or more consecutive axles, and N = number of axles in the group under consideration; except that 2 consecutive sets of tandem axles may carry a gross load of 34,000 pounds each if the first and last axles of the consecutive sets of tandem axles are not less than 36 feet apart, and the gross vehicle weight does not exceed 80,000 pounds including all enforcement tolerances. Except for 5 axle truck tractor, semi-trailer combinations having 2 consecutive sets of tandem axles, vehicles having a gross weight in excess of 80,000 pounds or in excess of the vehicle gross weight determined by application of the formula in this subsection shall be subject to the maximum axle loads specified in column 2 (Normal Loadings When Seasonal Load Limitations Are Not In Force).

A vehicle or combination of vehicles when utilizing an additional 5 miles from a "Special Designated Highway" for access to or from points of origin or destination, must reduce to the following axle weights when the route being traveled is under seasonal load limitations: Rigid route — 15,000 lbs. on a single axle, 12,750 lbs. per axle on a tandem axle assembly. Flexible route — 13,000 lbs. on a single axle, 11,050 lbs. per axle on a tandem axle assembly.

- \* On any legal combination of vehicles, only one (1) tandem axle assembly shall be permitted at the gross weight of 16,000 lbs. per axle and no other tandem axle assembly in such combination of vehicles shall exceed a gross weight of 13,000 lbs. per axle. When the gross weight of a combination of vehicles with load, does not exceed 73,280 lbs., two (2) tandem axle assemblies shall be permitted at a gross weight of 16,000 lbs. per axle.
- \*\* On any legal combination of vehicles, only one (1) tandem axle assembly shall be permitted at the gross weight of 12,000 lbs. per axle and no other tandem axle assembly in such combination of vehicles shall exceed a gross weight of 9,750 lbs. per axle. When the gross weight of a combination of vehicles with load does not exceed 73,280 lbs., two (2) tandem axle assemblies shall be permitted at a gross weight of 12,000 lbs. per axle.
- \*\*\* On any legal combination of vehicles, only one (1) tandem axle assembly shall be permitted at the gross weight of 10,400 lbs. per axle and no other tandem axle assembly in such combination of vehicles shall exceed a gross weight of 8,450 lbs. per axle. When the gross weight of a combination of vehicles with load does not exceed 73,280 lbs., two (2) tandem axle assemblies shall be permitted at a gross weight of 10,400 lbs. per axle.

The following examples are shown as a guide for figuring the maximum allowable gross axle loads on all State Trunk Lines during all periods of the year.

- **MINIMUM TIRE REQUIREMENTS:** The maximum load on any wheel shall not exceed 700 pounds per inch of tire width.

Illustrations of axle spacings:

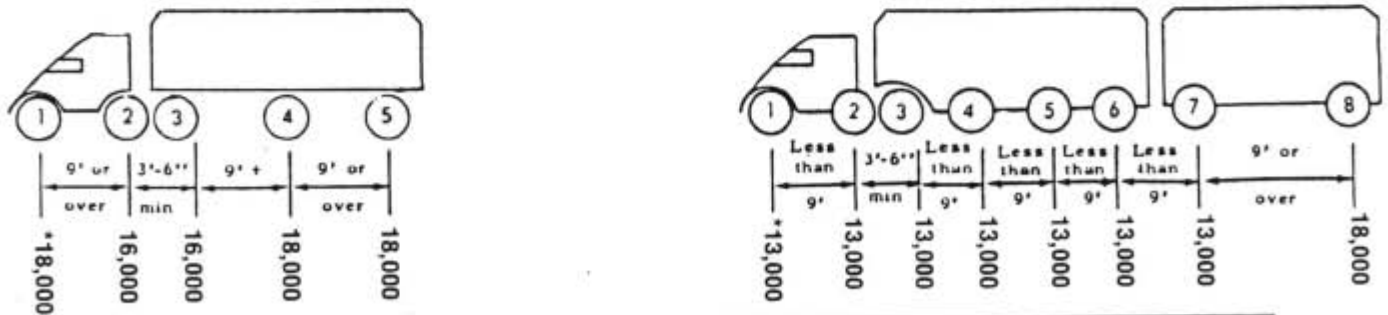

**Public Act # 300, 1949, Sec. 257.722 Paragraph 3**

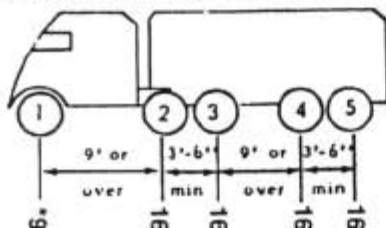

"When the maximum gross weight of a combination of vehicles with load does not exceed 73,280 pounds, 2 tandem axle assemblies shall be permitted at a gross permissible weight of 16,000 pounds for any such individual axle."

MIDLAND COUNTY ROAD COMMISSION  
 2334 N. Meridian Road  
 SANFORD, MICHIGAN 48657

# Weight

Speed Limit 35 MPH  
 Based on tire size 10.100 x 20  
 (11.100 x 20 are better)

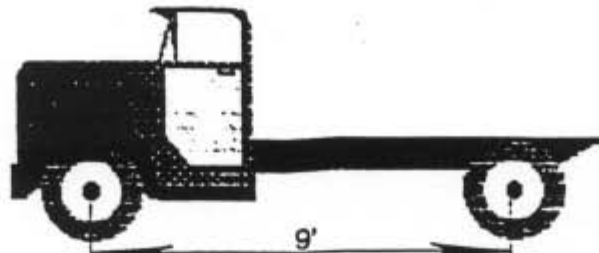

Normal Loading	<u>14,000</u>	<u>18,000</u>
Frost Law Restriction	9,100	11,700

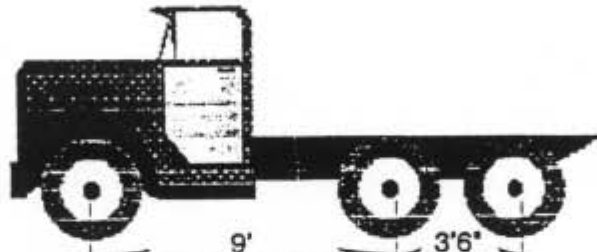

Normal Loading	<u>14,000</u>	<u>16,000</u>	<u>16,000</u>
Frost Law Restriction	9,100	10,400	10,400

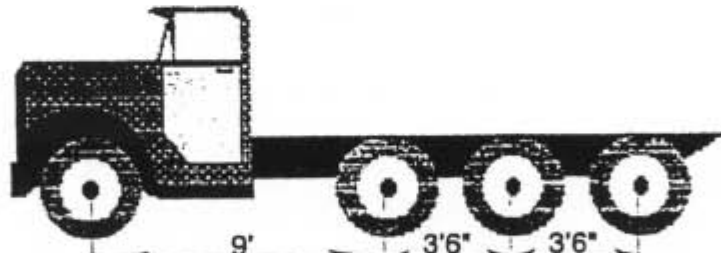

Normal Loading	<u>14,000</u>	<u>13,000</u>	<u>13,000</u>	<u>13,000</u>
Frost Law Restriction	9,100	8,450	8,450	8,450

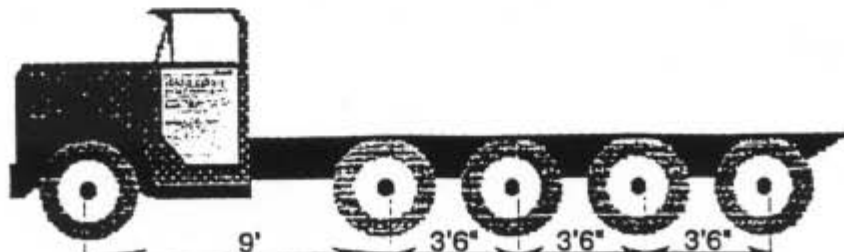

Normal Loading	<u>14,000</u>	<u>13,000</u>	<u>13,000</u>	<u>13,000</u>	<u>13,000</u>
Frost Law Restriction	9,100	8,450	8,450	8,450	8,450

# Weight

